

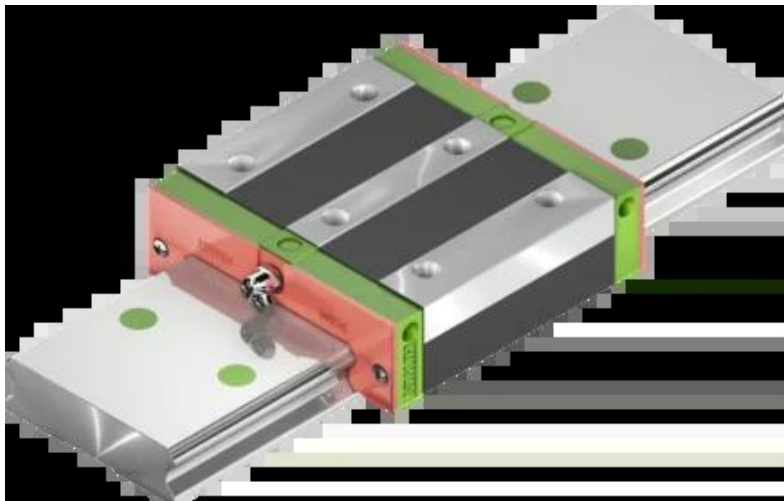

Wózek liniowy WEH50CAZAH seria WE-QW - HIWIN



**Numer artykułu SKU:
OC-HIWIN000651**

Numer artykułu producenta:

Czas wysyłki: Do 3-5 dni

HIWIN[®]

OPIS PRODUKTU

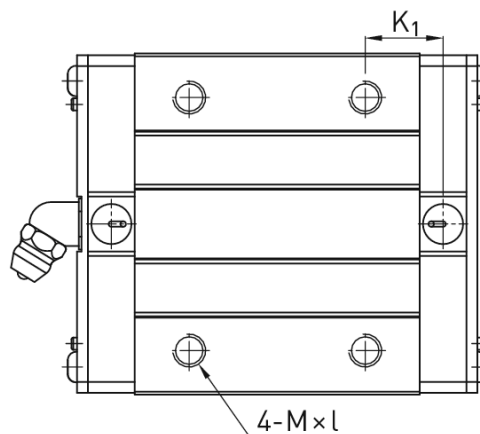

WE_17
WE/QW_21

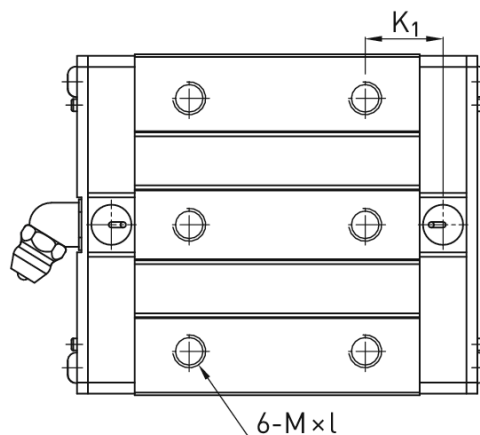

WE/QW_27
WE/QW_35
WE_50

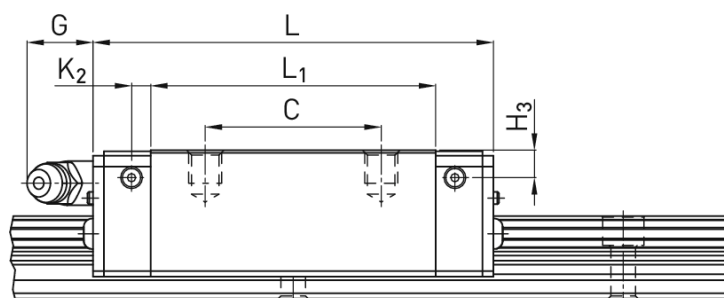
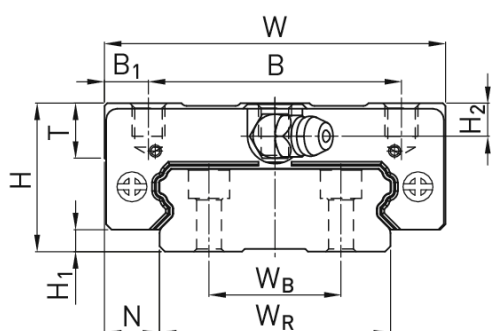

Wymiary montażowe

H	Wysokość całkowita	50	mm
H ₁		7,5	mm
N		20	mm
W	Szerokość wózka	130	mm
B		100	mm
B ₁		15	mm
C		65	mm
L ₁		112	mm
L	Długość wózka	140	mm
K ₁		28,05	mm

K_2	6	mm
G	12,9	mm
M	M10	
I	15	mm
T	19,5	mm
H_2	12	mm
H_3	10,5	mm
Masa	3,16	kg

Nośności i momenty

C_{dyn}	Nośność dynamiczna	61.520	N
C_0	Nośność statyczna	97.000	N
M_{0x}	Moment statyczny	4.030	Nm
M_{0y}	Moment statyczny	1.960	Nm
M_{0z}	Moment statyczny	1.960	Nm

DANE TECHNICZNE

Nr kat.

OC-HIWIN000651