

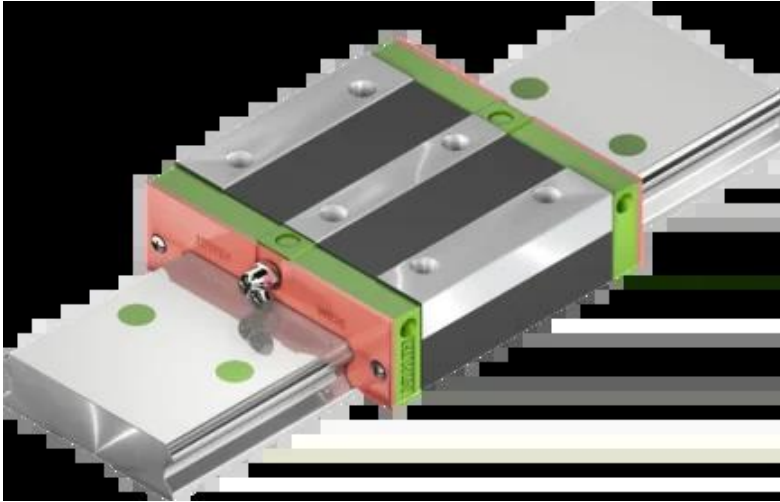

Wózek liniowy WEH21CAZ0H seria WE-QW - HIWIN



**Numer artykułu SKU:
OC-HIWIN000608**

Numer artykułu producenta:

Czas wysyłki: Natychmiast

HIWIN[®]

OPIS PRODUKTU

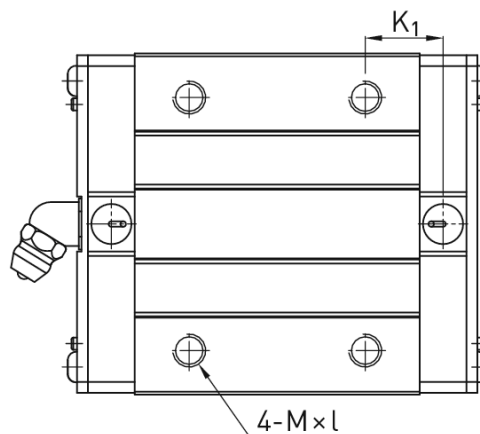

WE_17
WE/QW_21

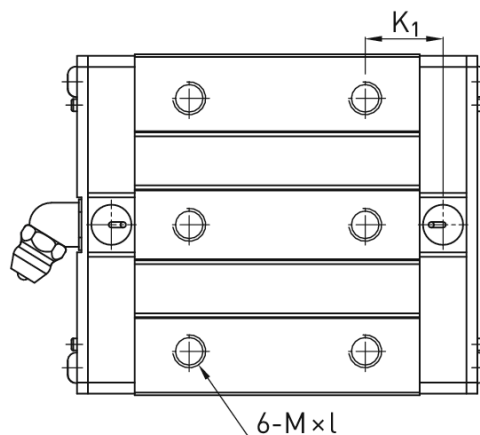

WE/QW_27
WE/QW_35
WE_50

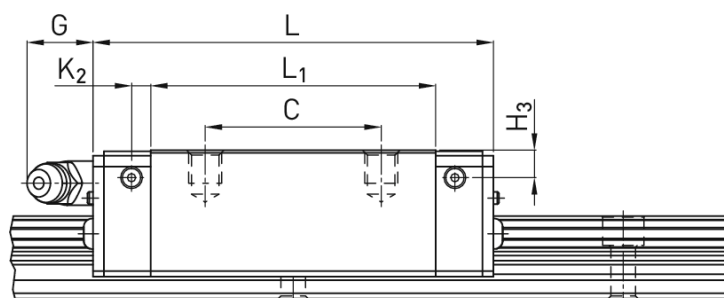
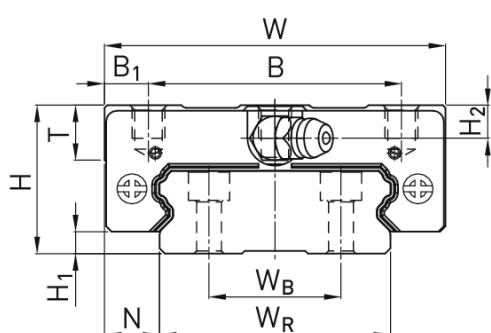

Wymiary montażowe

H	Wysokość całkowita	21	mm
H ₁		3	mm
N		8,5	mm
W	Szerokość wózka	54	mm
B		31	mm
B ₁		11,5	mm
C		19	mm
L ₁		41,7	mm
L	Długość wózka	59	mm
K ₁		14,68	mm

K_2	3,65	mm
G	12	mm
M	M5	
I	6	mm
T	8	mm
H_2	4,5	mm
H_3	4,2	mm
Masa	0,2	kg

Nośności i momenty

C_{dyn}	Nośność dynamiczna	7.210	N
C_0	Nośność statyczna	13.700	N
M_{0x}	Moment statyczny	230	Nm
M_{0y}	Moment statyczny	100	Nm
M_{0z}	Moment statyczny	100	Nm

DANE TECHNICZNE

Nr kat.

OC-HIWIN000608

Data wygenerowania podsumowania: 06.06.2026r, g. 00:40